

# POSI-CONTROL

Position control

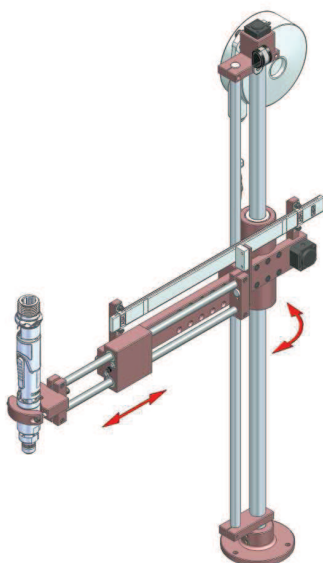

Linear arms BA...PC series

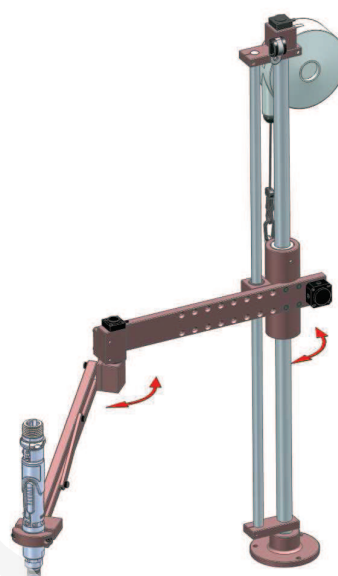

Articulated arms BA...RPC series

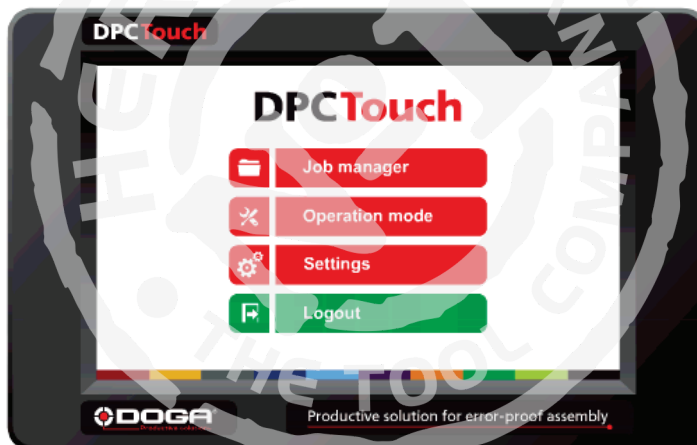

- Zero fault process
- Error proofing
- Sequencing
- Suitable with air and electric tools
- Automation device management

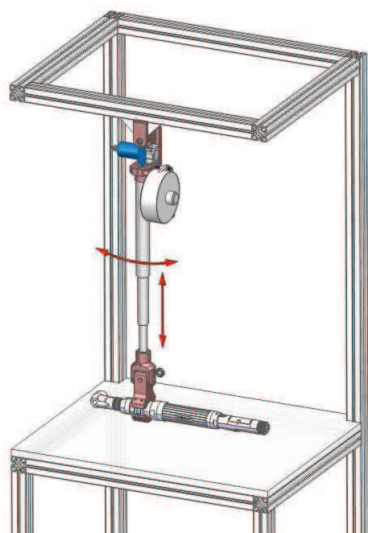

Telescoping arms DMF...PC series

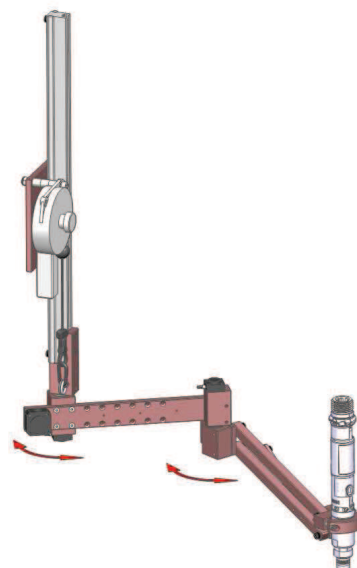

Suspended arms Slider BA...RPC series

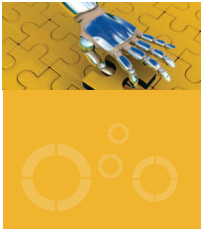

# POSI-CONTROL System

- Open job structure allows set up of customized logical sequences of fastenings, messages and I/O's.

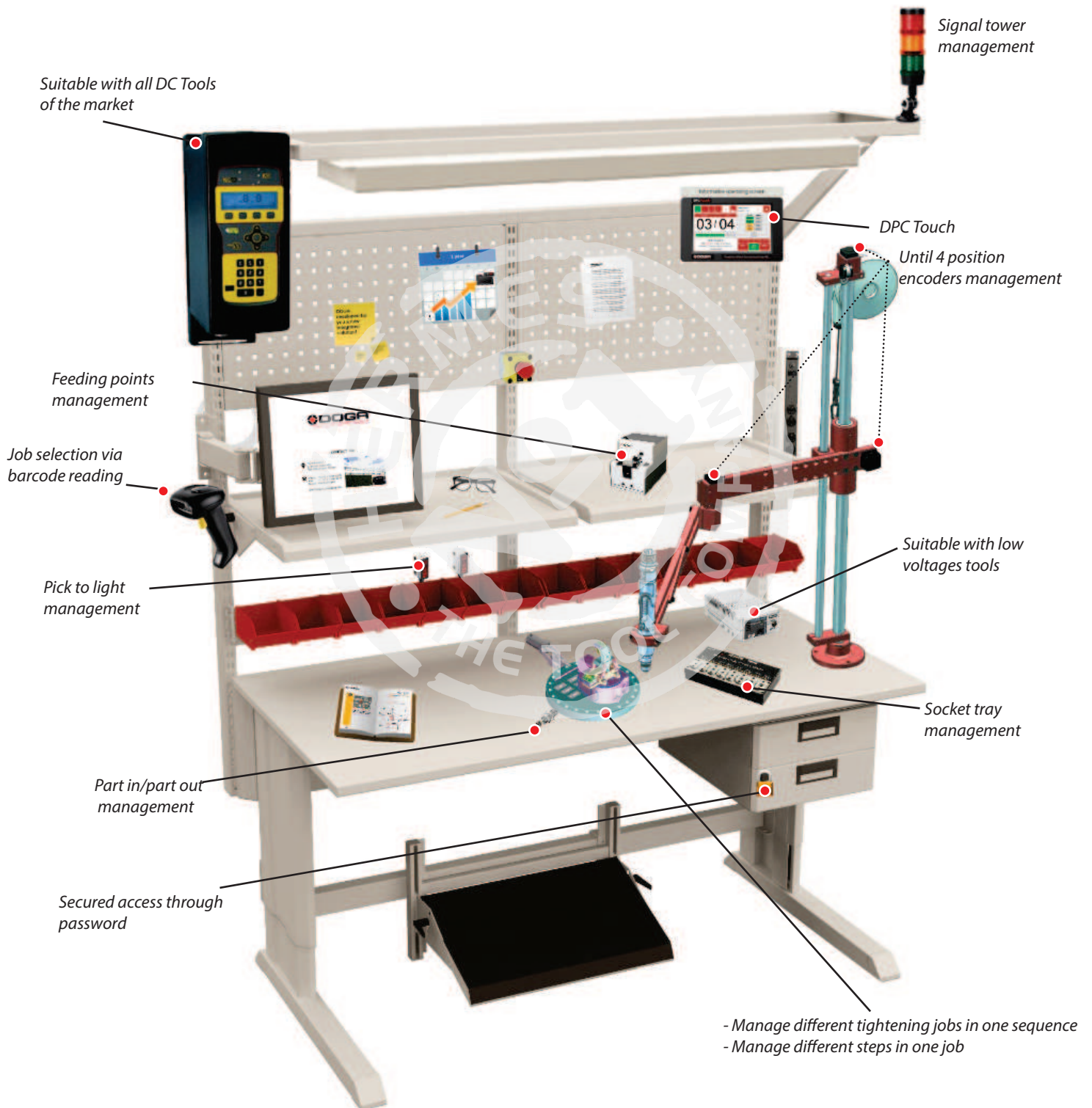

- More than a sequencing and Poka-Yoke controller the DPC Touch may easily manage the automation devices of your workstation on assembly line.

# POSI-CONTROL DPC-Touch

Powerful - user friendly - versatile



• TECHNICAL FEATURES :

Dimensions : 202 x 127 x 38 mm

Weight : 550 gr

I/O's : 12 inputs, 12 outputs, 24 Volts

LCD screen : 7" touch screen (800 x 480 m/m)

Encoders : until 4 encoders, (0 - 5 V)

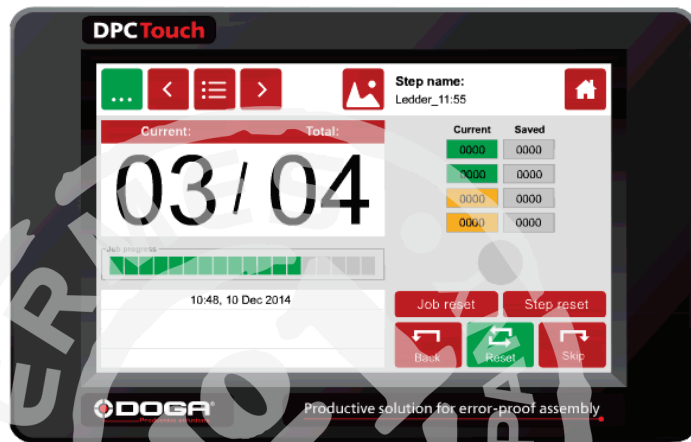

Power supply

2 ports for low voltage DOGA screwdrivers

12 inputs/12 outputs (assignable)

Encoders port

RS232 port (firmware upgrade and bar code reading/Job selection)

• Fast and powerful :

- In house operating system
- Until 999 programable jobs !
- Until 255 steps per jobs !
- Until 99 positions per step !
- Until 4 position encoders

• Versatile :

- Suitable with all DC Tools - low voltage and air tools
- Poka-Yoke or/and sequencing controller
- Assignable I/O's
- Suitable with screwfeeders pick up
- Opened job structure enables customized logical sequences
- Management of your automation devices

• User friendly :

- Embedded soft
- Touch screen
- Self teaching sequencing
- Smart tolerance detection
- Process and sequencing visualization - operator instructions guidance

Model	Code
DPC Touch	6-1274100
DPC Touch / GX, GY, DO, GA cable	6-1041620
DPC Touch / DOGA HD, SD cable	6-1252002
DPC Touch / Stanley TAU/THETA cable	4-1241036
DPC Touch / Stanley KAPPA, ALPHA cable	4-1241050
DB9 3m/free wires (4 outputs/3 inputs) cable	4-1200542
DB25 3m/free wires (9 outputs/12 inputs) cable	4-1200770
DB44 3m/free wires (12 outputs/12 inputs) cable	6-1041621
Air kit for pneumatic tool / DPC Touch	4-1200771
Firmware upgrade kit	6-1200004



# Linear arms

## BA...PC Series

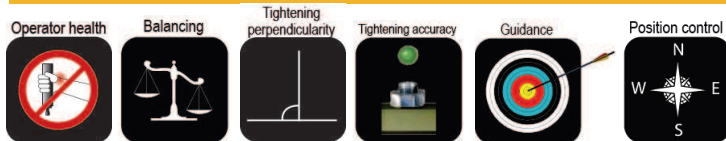

- Torque up to 100 Nm
- Equipped with absolute angle encoders (12 bits)
- Higher torque is available on request

### BA 12/25/40/100 PC

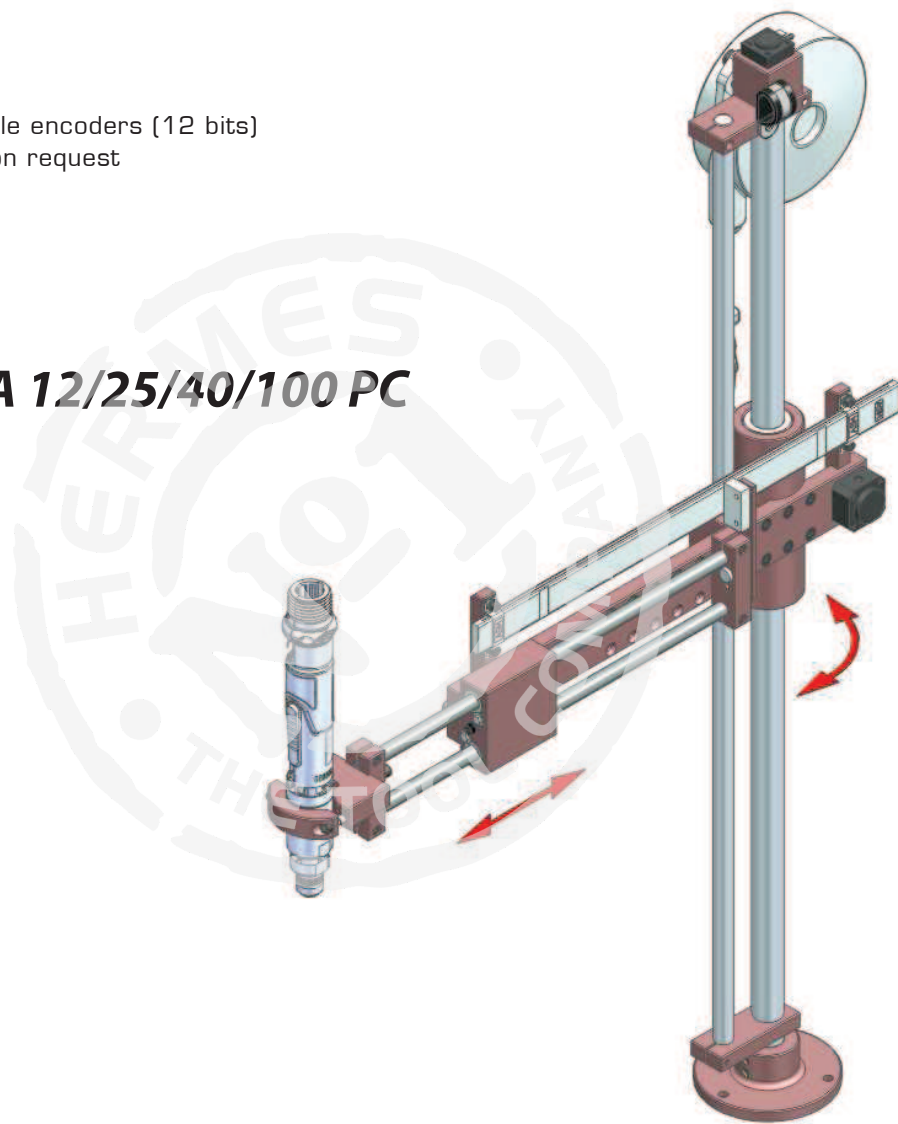

Model	Max torque (Nm)	Tool Ø (mm)	Stroke (mm)	Max load (Kg)	Code
BA 12 PC	12	25 - 50	195	1,2	4-1201009
BA 25 PC	25	28 - 52	195	2,2	4-1201086
BA 40 PC	40	28 - 52	295	3	4-1201087
BA 40 PC/400	40	28 - 52	395	3	4-1201088
BA 100 PC	100	28 - 52	295	4	4-1201089
BA 100 PC/400	100	28 - 52	395	4	4-1201091

# Linear arms

## BA...PC Dimensions

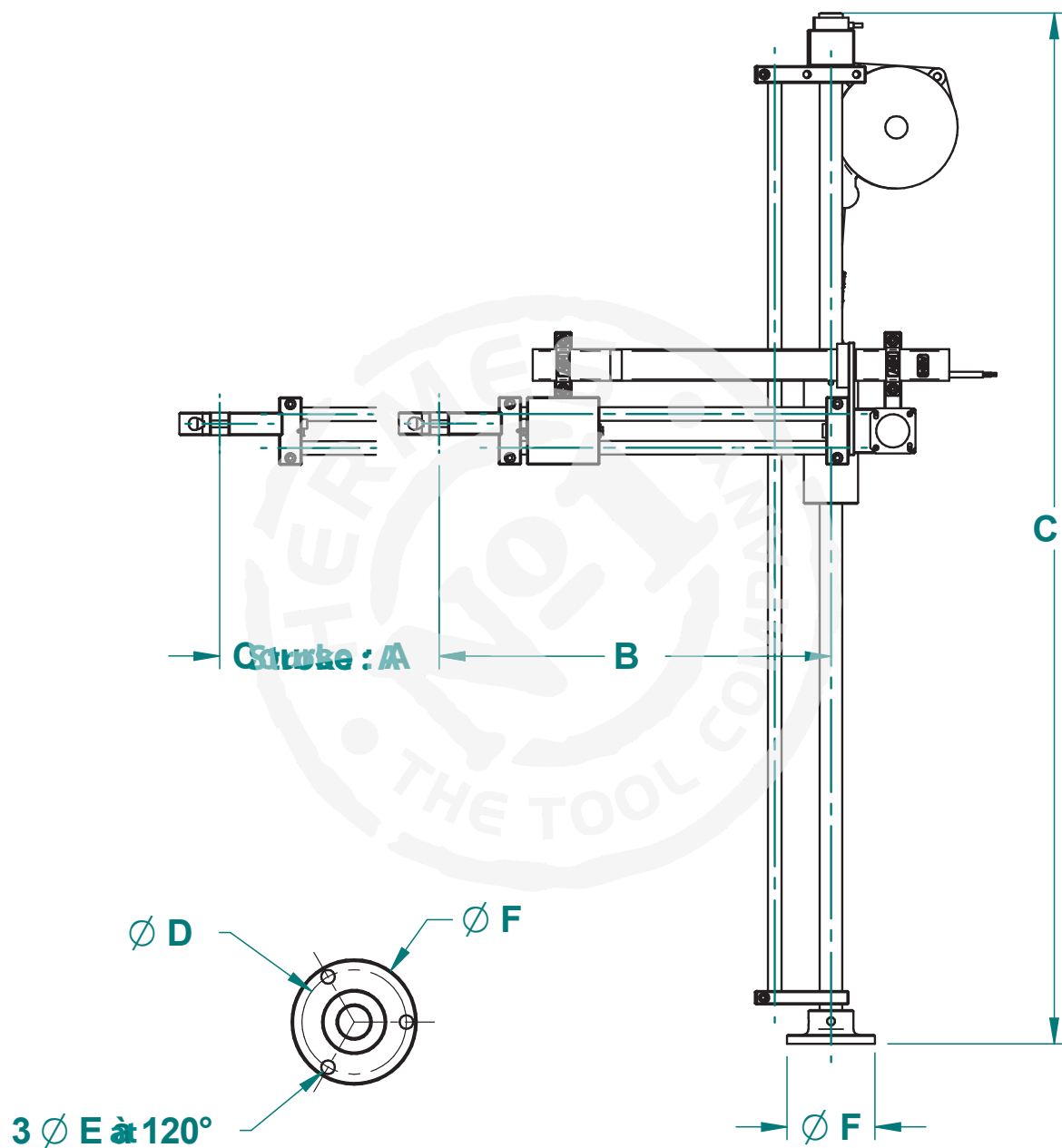

Model	Stroke A	B mini	B maxi	C	D	E	F
BA 12 PC	195	236	336	816	65	8,5	78
BA 25 PC	195	251	351	916	65	8,5	78
BA 40 PC/300	295	320	470	1016	100	8,5	118
BA 40 PC/400	395	420	570	1016	100	8,5	118
BA 100 PC/300	295	335	485	1016	126	10,5	148
BA 100 PC/400	395	435	585	1016	126	10,5	148



# Articulated arms

## BA...RPC Series

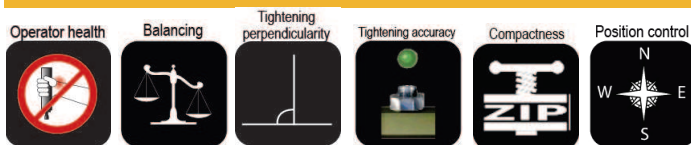

- Torque up to 100 Nm
- Operating range up to 1100 mm
- Equipped with two absolute angle encoders 12 bits (0,1°)
- Higher torque is available on request

### BA 12/25/40/100 RPC

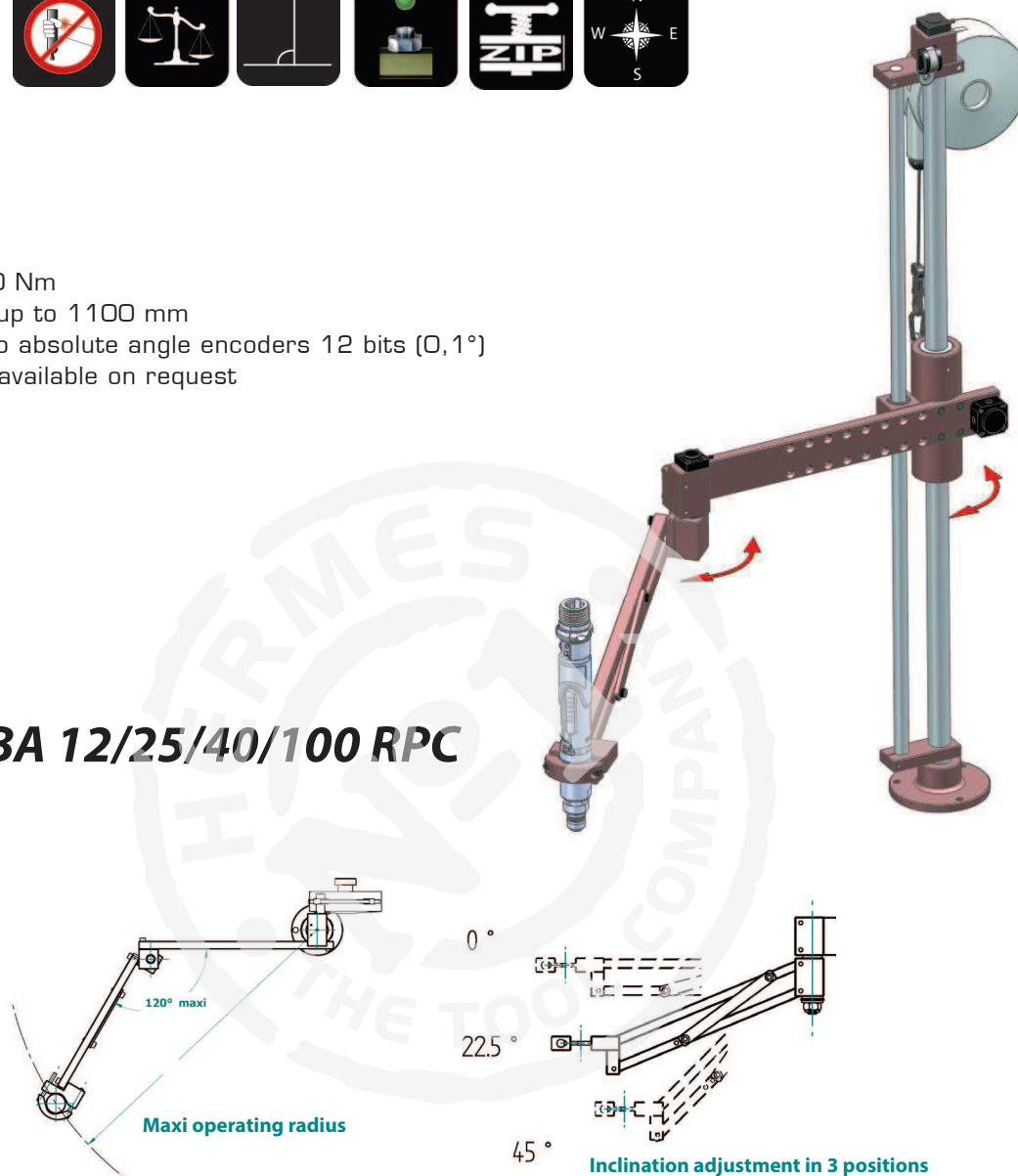

Model	Max torque (Nm)	Tool Ø (mm)	Operating range (mm)	Max load (Kg)	Code
BA 12 RPC	12	25 - 50	450	1,2	4-1201010
BA 25 RPC	25	28 - 52	460	2,2	4-1200472
BA 25 RPC/600	25	28 - 52	600	2,2	4-1200475
BA 40 RPC	40	28 - 52	650	3	4-1200473
BA 40 RPC/800	40	28 - 52	800	3	4-1200476
BA 100 RPC	100	28 - 52	730	4	4-1200474
BA 100 RPC/900	100	28 - 52	900	4	4-1200477
BA 100 RPC/1100	100	28 - 52	1100	4	4-1200478

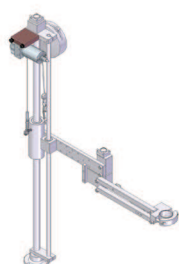

### Option

Z encoder / BA RPC. **Code : 4-1283125.**  
Encoder cable Z. **Code 4-1200725.**

# Articulated arms

## BA...RPC Series Dimensions

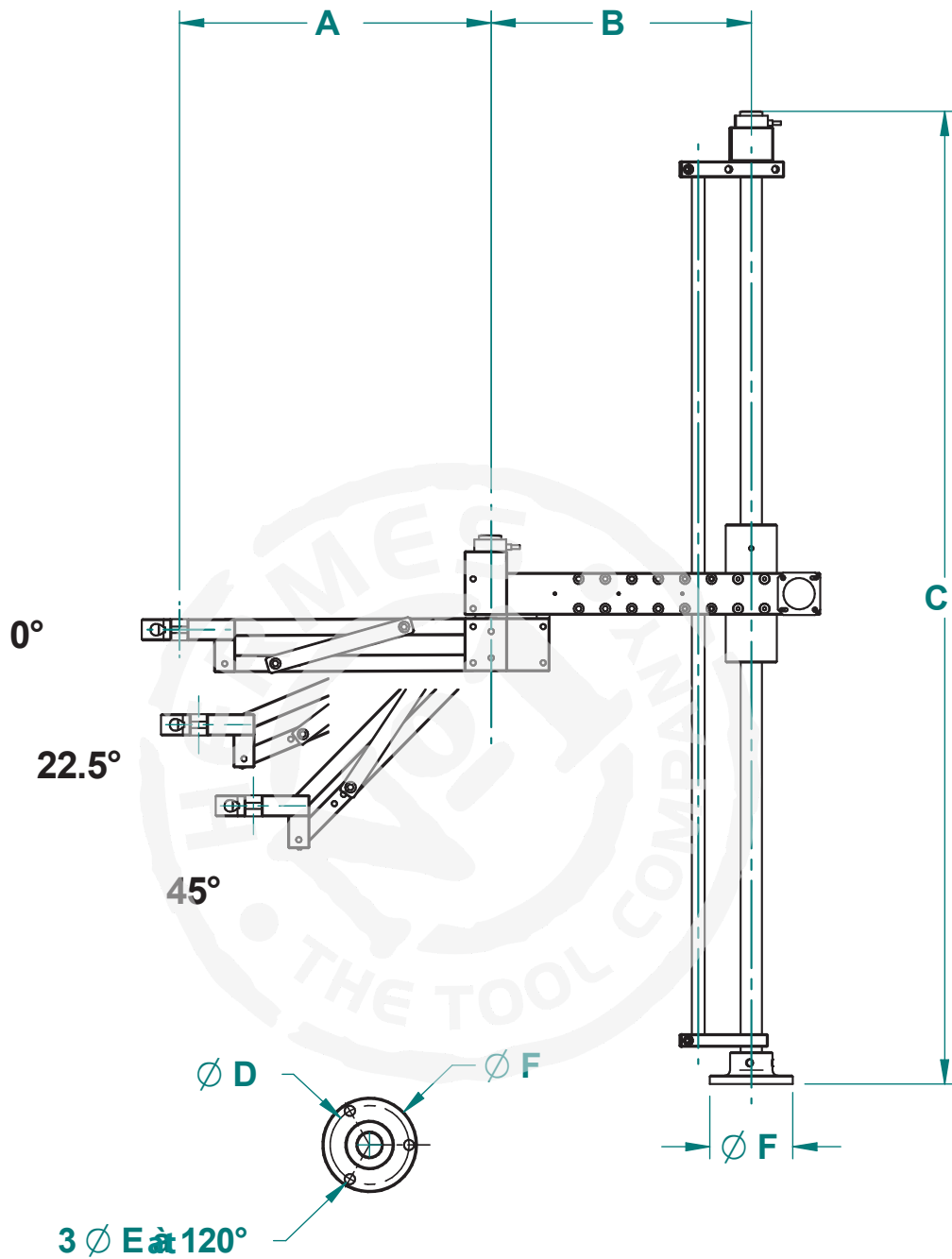

Model	A 0°	A 22.5°	A 45°	B min	B max	C	Operating range at 22.5°
BA 12 RPC	279	261	209	145	245	816	450
BA 25 RPC	296	278	227	145	245	916	460
BA 25 RPC/600	358	336	271	330	330	916	600
BA 40 RPC	414	387,5	310,5	200	350	1016	650
BA 40 RPC/800	503	470	374	415	415	1016	800
BA 100 RPC	462	433	351	255	405	1016	730
BA 100 RPC/900	564	528	425	520	520	1016	900
BA 100 RPC/1100	694	648	517	635	635	1016	1100

D, E, F similar to BA...R



# Carbon telescoping arms

## DMF...PC Series

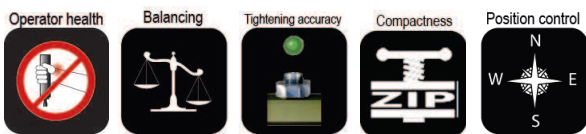

- Torque up to 140 Nm
  - Equipped with absolute angle encoders 12 bits (0,1°)
- ↔ Monitored movement

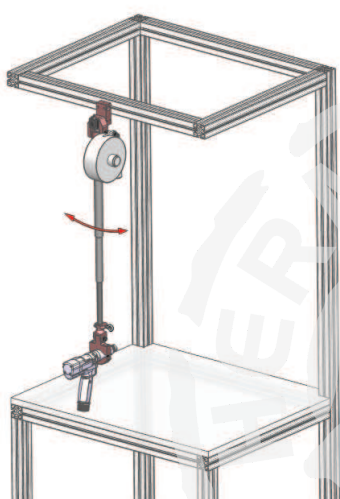

**DMF APC**  
Equipped with one angle encoder

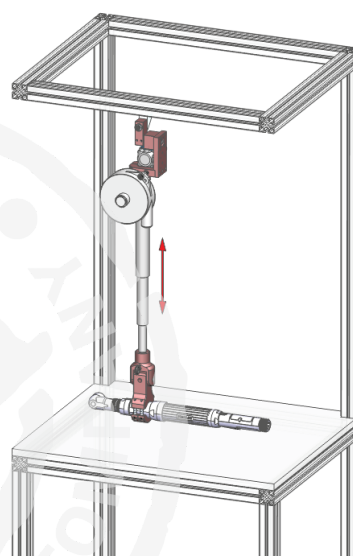

**DMF LPC**  
Equipped with one length encoder

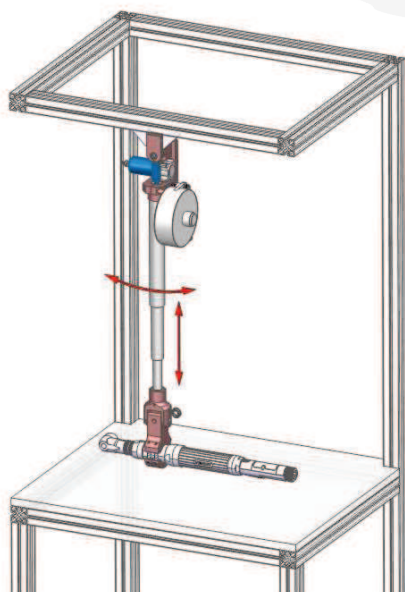

**DMF LAPC**  
Equipped with one length encoder and one angle encoder

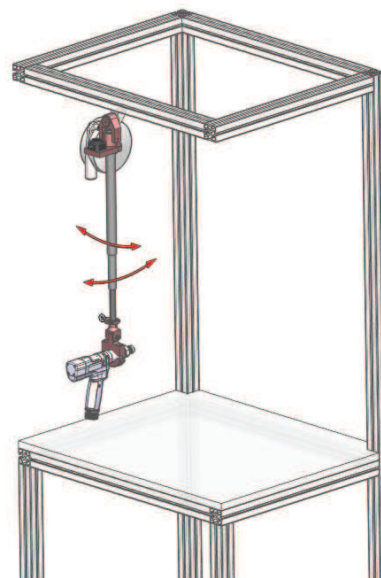

**DMF AAPC**  
Equipped with two angle encoders (inclinometer)



# Carbon telescoping arms

## DMF...PC Series

### DMF APC

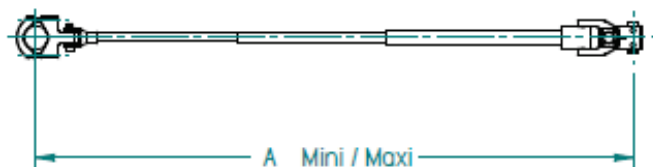

### DMF LPC/LAPC

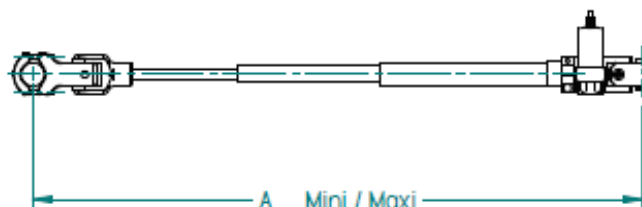

Model	Torque	Clamp	Tool Ø	Min	Max	Code without clamp	Code with clamp
DMF 30 APC/960	30	P1	28-52	560	960	4-1200574	4-1200564
DMF 30 APC/1500	30	P1		706	1500	4-1200575	4-1200565
DMF 30 APC/2000	30	P1		873	2000	4-1200576	4-1200566
DMF 80 APC/1500	80	P2/P3	35-52	764	1500	4-1200577	4-1200567
DMF 80 APC/2000	80	P2/P3		930	2000	4-1200578	4-1200568
DMF 140 APC/1500	140	P2/P3		978	1500	4-1200579	4-1200569
DMF 140 APC/2000	140	P2/P3		1228	2000	4-1200580	4-1200572
DMF 30 LPC/960	30	P1	28-52	560	960	4-1200588	4-1200581
DMF 30 LPC/1500	30	P1		727	1500	4-1200589	4-1200582
DMF 30 LPC/2000	30	P1		894	2000	4-1200590	4-1200583
DMF 80 LPC/1500	80	P2/P3	35-52	780	1500	4-1200591	4-1200584
DMF 80 LPC/2000	80	P2/P3		947	2000	4-1200592	4-1200585
DMF 140 LPC/1500	140	P2/P3		991	1500	4-1200593	4-1200586
DMF 140 LPC/2000	140	P2/P3		1241	2000	4-1200594	4-1200587
DMF 30 LAPC/960	30	P1	28-52	560	960	4-1200662	4-1200595
DMF 30 LAPC/1500	30	P1		727	1500	4-1200663	4-1200596
DMF 30 LAPC/2000	30	P1		894	2000	4-1200664	4-1200597
DMF 80 LAPC/1500	80	P2/P3	35-52	780	1500	4-1200665	4-1200598
DMF 80 LAPC/2000	80	P2/P3		947	2000	4-1200666	4-1200599
DMF 140 LAPC/1500	140	P2/P3		991	1500	4-1200667	4-1200660
DMF 140 LAPC/2000	140	P2/P3		1241	2000	4-1200668	4-1200661

### AAPC Option

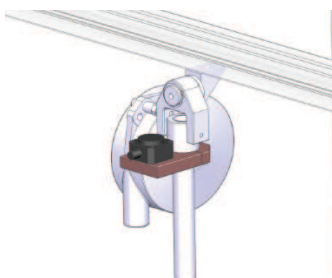

*Inclinometer may be installed on standard DMF arms (DMF30, DMFi 70/120/200) to monitor angular position.*

For	Code
DMF 30	4-1200809
DMFi 70/120/200	4-1200810



# Carbon telescoping arms

## Clamps for DMF...PC

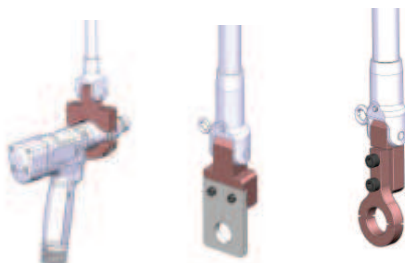

### P1 clamp

For	P1	Tool Ø
DMF 30	Standard	28/52
DMF 80/140	Mounting plate interface	On request

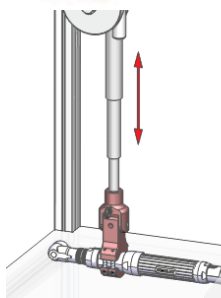

### P2 clamp

For	Tool Ø	Code
DMF 30	28/52	4-1200301
DMF 80/140	35/52	Standard



### P3 clamp

For	Tool Ø	Code
DMF 30	28/52	4-1200301
DMF 80/140	35/52	Standard



### P4 clamp

For	Tool Ø	Code
DMF 30	28/52	4-1200302
DMF 80/140	35/52	4-1200343



### Tilt interface

For	Code
DMF 30 30°	4-1201140
DMF 30 45°	4-1201141

### Swivel clamp

For	Tool Ø	Code
DMF 80/140	On request	On request

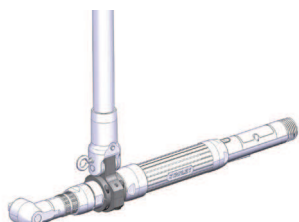

### P2 Rotating clamp

For	Tool Ø	Code
DMF 30	On request	4-1201134
DMF 80/140	On request	4-1201135

# Carbon telescoping arms

## DMF...PC Accessories

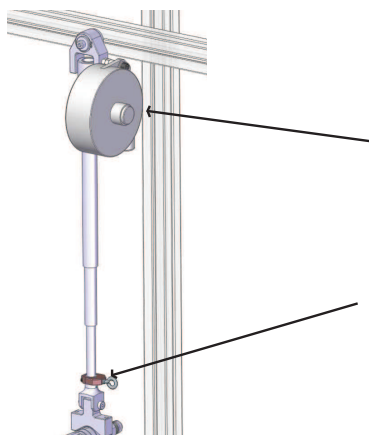

### Balancing kit for DMF...PC

Max load tool (kg)	For	Code
1/2,5	DMF 30	4-1200304
2/4	DMF 30/80	4-1200305
4/6	DMF 80/140	4-1200306

Balancer attachment kit for DMF30 **Code 4-1201143.**

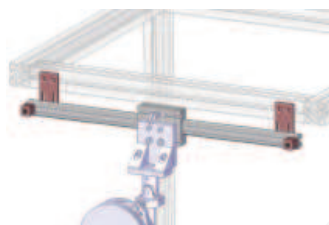

### Rails

Length	Stroke	Number of flanges	Code
600	450	2	4-1200132
800	650	2	4-1200160
1000	850	2	4-1200161
1200	1050	3	4-1200162
1500	1350	3	4-1200163
2000	1850	4	4-1200164

### Rail interface

Allows installation of DMF on rail.

For	Code
DMF 30/80/140	4-1200341
DMF 300	4-1200342

**NOTE** : delivered without safety hook (**Code 4-1200309**)

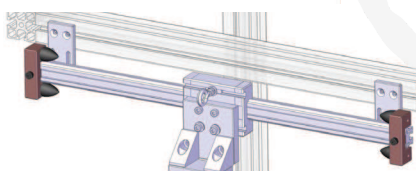

### Absorbing stop

Recommended in case of repeatable side shocks.

**Code 4-1201121** Set of 2

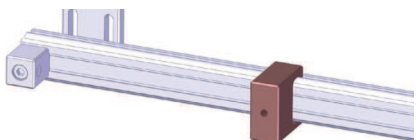

### Adjustable stop

To limit the slide of the arm on the rail.

**Code 4-1200167**

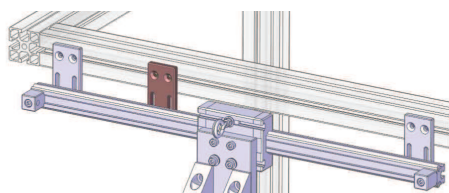

### Additional flange

To reinforce the rail installation for high torque applications.

**Code 4-1200873**

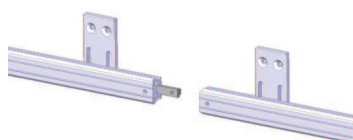

### Rail link

To link two rails together.

**Code 4-1200307**